

## 9.5 Add or Remove Samples in Single Access Mode

---

With this function it is possible to add or remove samples from the cassette. All actions with the **Add** or the **Remove** button apply to the **Operator Access Position**.

---

**i** The laboratory supervisor is responsible for adding/removing samples. Never add or remove samples without the permission of the laboratory supervisor.

---



Figure 9.9 Main Menu Touch Screen Buttons

## 9.5.1 Adding Samples

1. Press the **Add** button.
  - The Add selection window appears displaying 3 buttons: When no empty position is left, the **Go to free** button is disabled and grayed.

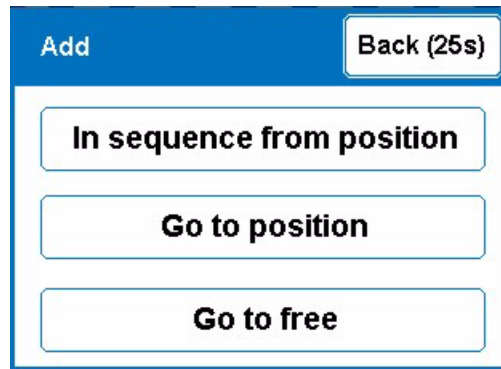

Figure 9.10 The Add Selection Window

2. Press the **Go To Position** button to choose the sample position.
  - The Position selection screen appears:

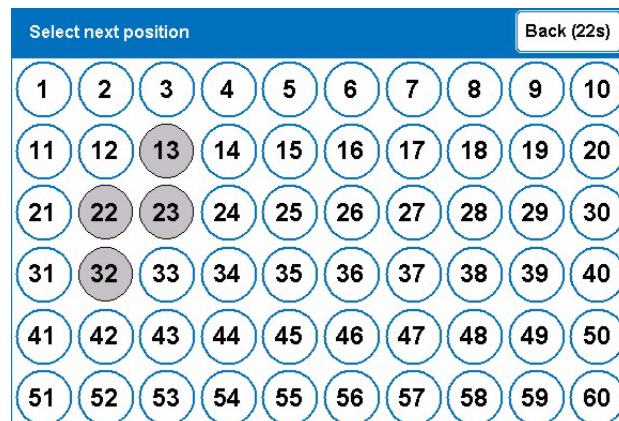

Figure 9.11 Position Selection Screen

3. Select an empty gray position to insert the sample into (white positions are loaded with samples).
  - The conveyor chain rotates the selected position to the **Operator Access Position**, during which a message is displayed on the screen:



Figure 9.12 Going to the Operator Access Position

- When the operator access position is reached the following message is displayed:

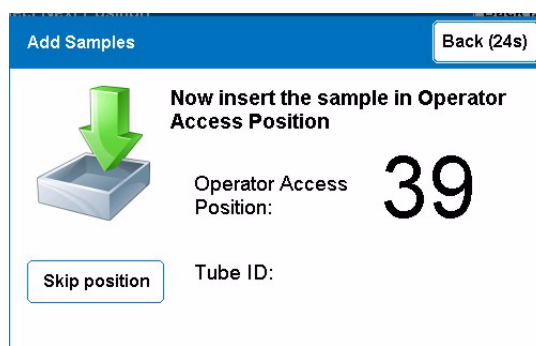

Figure 9.13 Insert Sample Screen

4. Insert the sample into the **Operator Access Position** (Figure 9.14/1).

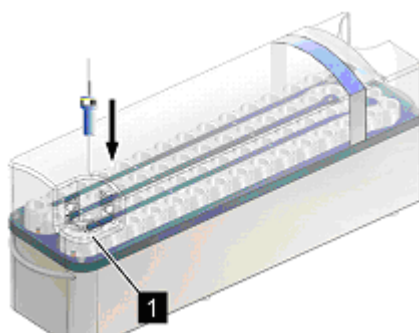

Figure 9.14 Operator Access Position



Note: Make sure the sample height is within the limits set in "Sample Adjustment and Maximum Sample Height" on page 60.

- The selection screen (Figure 9.11) will be displayed again:

5. To finish this function,
  - ▶ press the Back button,
  - or
  - To add another sample,
    - ▶ press a gray position,
    - or
    - To replace a sample,
      - ▶ press a white position. The following message is displayed:

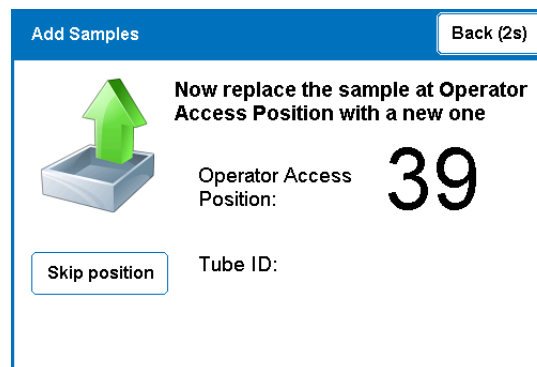

Figure 9.15 Replacing a Sample

### 9.5.1.1 Adding Samples - Go to Free Position

When samples do not need to be in any specific order, it is faster to add a sample in the nearest free position:

1. Press the **Add** button in the main screen.

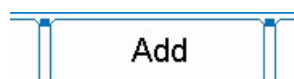

Figure 9.16 Add/Remove Button

- ▶ The Add selection screen is displayed:

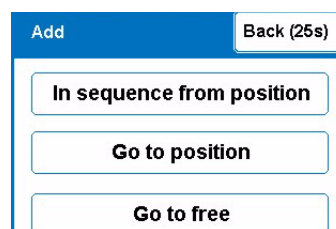

Figure 9.17 Go to free

2. Press the **Go to free** button.
  - The chain rotates to the next free position:

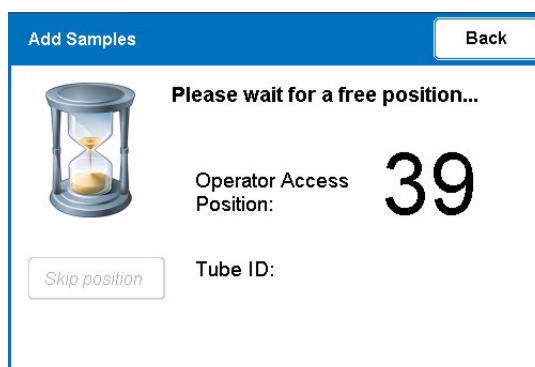

Figure 9.18 Waiting for a free position

3. Insert a new sample, or press the **Skip position** button to continue to the next available position:

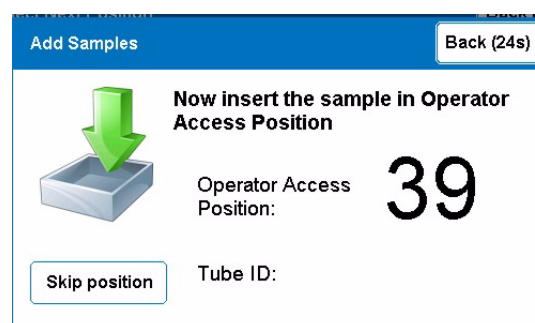

Figure 9.19 Inserting the Sample

- When a sample has been inserted, the chain rotates automatically to the next free position.

**Exception:** When the chain has been completely filled, an information screen is displayed:

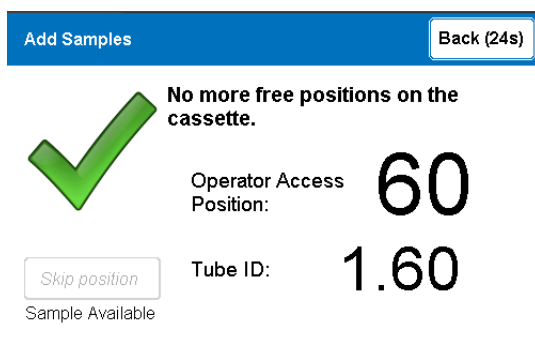

Figure 9.20 Display: No more free positions

4. When all samples have been inserted, press the **Back** button to return to the main menu.

### 9.5.1.2 Adding/Replacing Samples in Sequence

---

This functions allows samples to be added or replaced sequentially in ascending order, until the **Back** button is pressed.

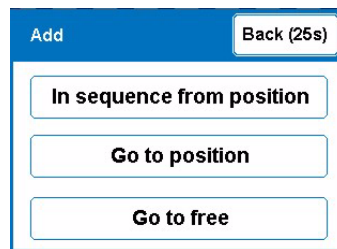

Figure 9.21 Removing Samples in Sequence from Position

1. Press the **Add** button (Figure 9.16) in the main screen.
  - The Add selection screen is displayed.
2. Press the **In sequence from position** button.
  - The Position selection screen appears.
3. Select an empty gray position for adding a sample or a filled position for replacing.
4. Add the sample to the position selected.
  - The chain rotates in ascending order to the next position, whereas another sample can be added or replaced.

Use the **Skip Sample** button to skip a sample. Use the **Back** button to return to the main menu.

## 9.5.2 Removing Samples

1. Press the **Remove** button (Figure 9.16) in the main screen.



- The Remove selection screen is displayed:

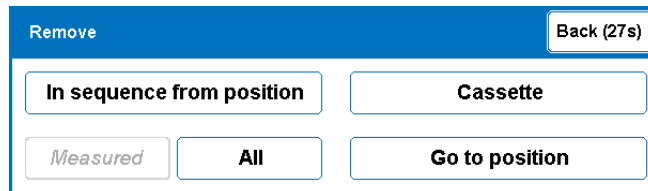

Figure 9.22 Remove Selection Screen

2. Press the **Go to position** button to choose the sample position.

- The Position selection screen appears:

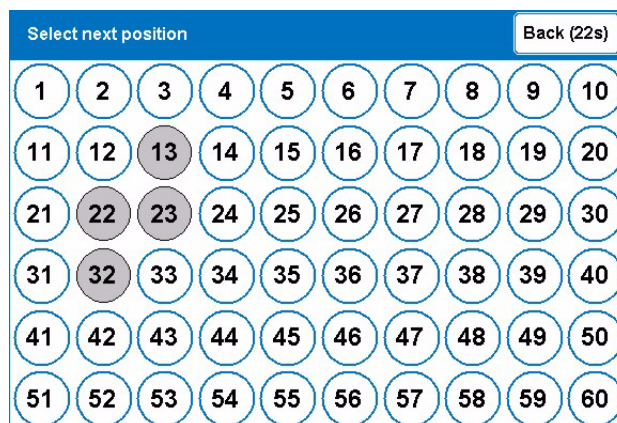

Figure 9.23 Position Selection Screen

3. Select a white (loaded) position for removing (gray positions are empty positions).

- While the conveyor chain rotates the selected position to the **Operator Access Position**, a message is displayed on the screen:

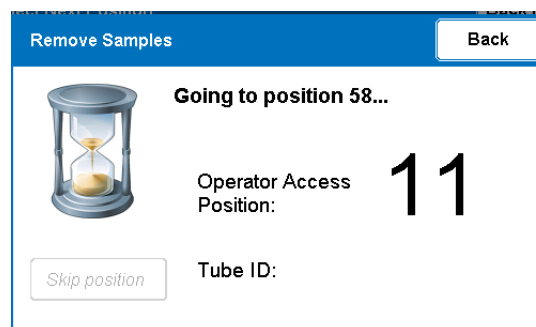

Figure 9.24 Going to Position

- ▶ When the sample arrives at the **Operator Access Position** the following message is displayed:

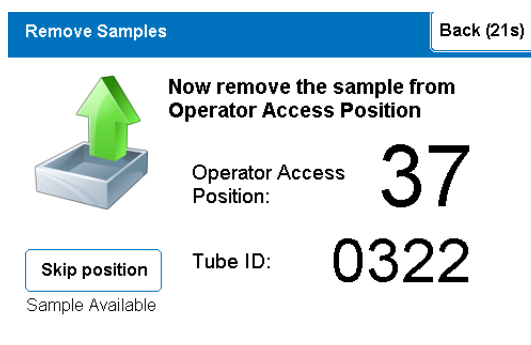

Figure 9.25 Remove Sample Screen

4. Remove the sample from the **Operator Access Position**.

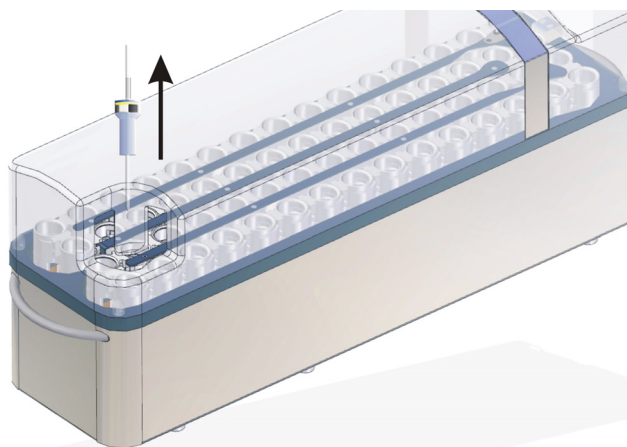

Figure 9.26 Operator Access Position

- ▶ The selection screen (Figure 9.11) will be displayed again.

5. To finish this function:
  - ▶ Press the Back button,
  - or
  - To remove another sample,
  - ▶ Press a white position.

### 9.5.2.1 Removing All the Samples

To remove all the samples individually through the **Operator Access Position**.

1. Press the **Remove** button (Figure 9.16) in the main screen.
  - ▶ The Remove selection screen is displayed.



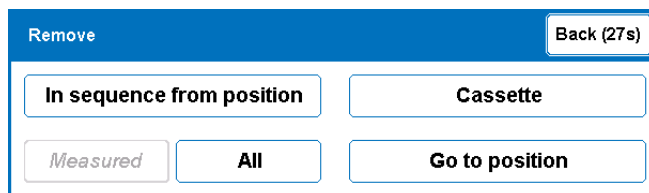

Figure 9.27 Remove All

2. Press the **All** button.
  - The chain rotates to the next position filled with a sample and a message is displayed:

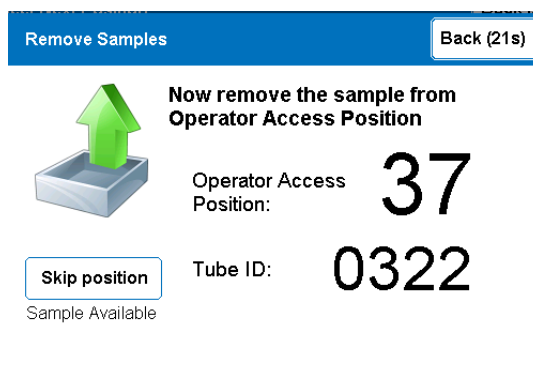

Figure 9.28 Removing the sample

3. Remove the sample.
  - The chain rotates to the next position filled with a sample.

This procedure will be repeated, until all samples are removed from the cassette. To skip a sample, press the **Skip position** button.

When all samples have been removed, a message is displayed that no more samples are in the cassette (apart from any skipped samples):

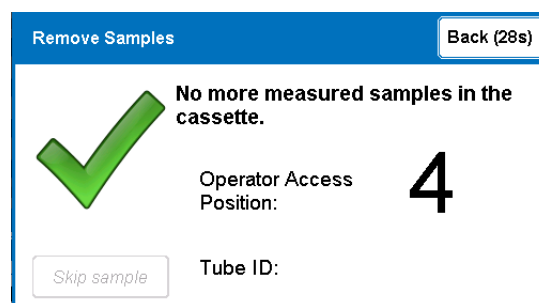

Figure 9.29 No more samples in the cassette

4. Press the **Back** button to return to the main menu.

## 9.5.2.2 Remove Measured Samples from the Cassette

It is possible to remove just the measured samples from the cassette. The measured sample positions are green colored, their state is **Finished**.

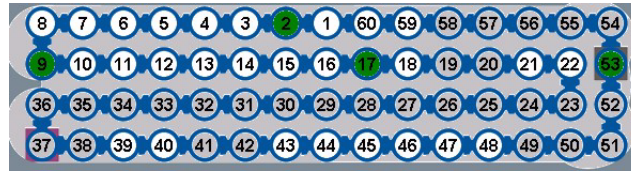

Figure 9.30 Finished Samples

To remove all measured samples individually through the **Operator Access Position**:

1. Press the **Remove** button (Figure 9.16) in the main screen.
  - When measured samples exist, the **Measured** button is enabled.
2. Press the **Measured** button.

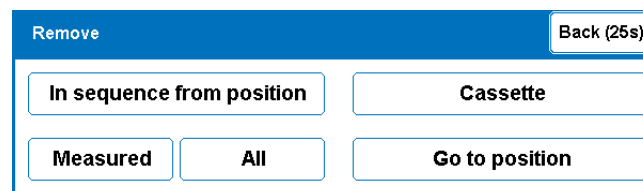

Figure 9.31 Remove Measured

- The chain rotates the nearest measured sample to the **Operator Access position**.

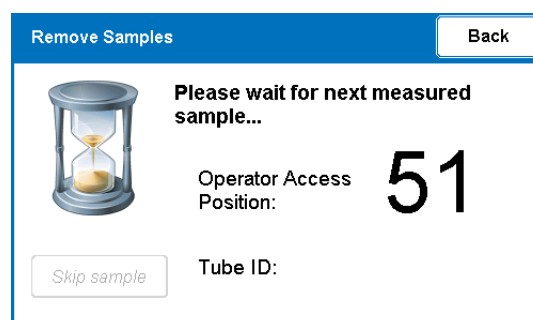

Figure 9.32 Removing Measured

When the measured sample arrives in the **Operator Access Position**, a message is displayed:

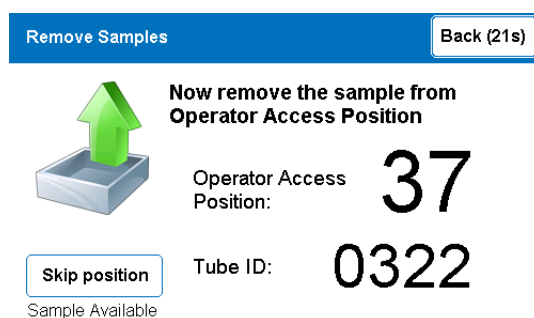

Figure 9.33 Removing finished samples

3. Remove the sample.

- The chain rotates to the next position filled with a measured sample.

This procedure will be repeated, until all measured samples are removed from the cassette. To skip a measured sample, press the **Skip Sample** button.

When all finished samples have been removed, a message is displayed that no more finished samples are in the cassette (apart from any skipped samples):

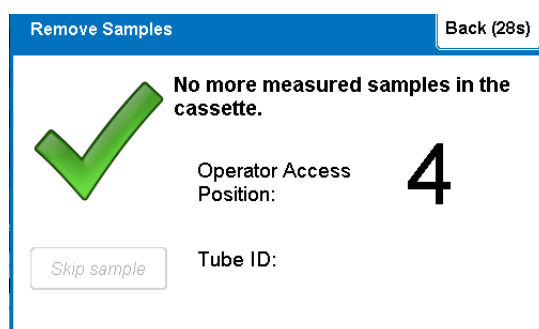

Figure 9.34 No more measured samples in the cassette

4. Press the **Back** button to return to the main menu.

### 9.5.2.3 Removing Samples in Sequence

---

This functions allows the removal of samples sequentially in ascending order from a selected position, until the next empty position is reached.

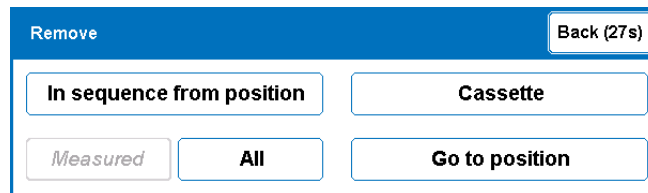

Figure 9.35 Removing Samples in Sequence from Position

1. Press the **Remove** button (Figure 9.16) in the main screen.
  - The Remove selection screen is displayed.
2. Press the **In sequence from position** button.
  - The Position selection screen appears.
3. Select a white (loaded) position for removing (gray positions are empty positions).

Use the **Skip Sample** button to skip a sample. Use the **Back** button to return to the main menu. See also the figures in chapter "Removing Samples" on page 74.

---